

Encoder Installation Manual

SERIES AI25 EtherNet/IP

Absolute Encoder

Document No.: 703291-0001
Revision Level: B
April 14, 2020

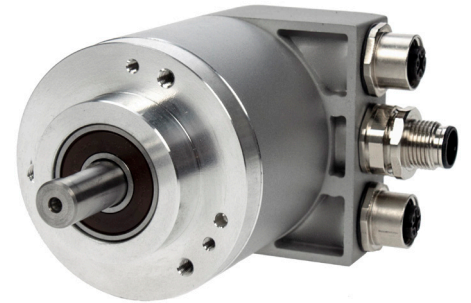

1. Preface

These installation instructions are provided for the connection and starting procedure of your Absolute Encoder.

You will get further information from the AI25 EtherNet/IP datasheet, on request, or by download from our Web Site at www.dynapar.com.

2. Safety

Authorized Personnel

The encoder should only be assembled and dismantled by a qualified person, as the unit contains sensitive electronic circuits.

Risk of Injury Due to Rotating Shafts

Hair, jewelry or articles of clothing may become caught in rotating shafts or other parts.

→ Prior to commencing all work, disconnect all power supplies and ensure that the working environment is safe!

Risk of Destruction Due to Static Electricity

The CMOS modules contained in the encoder are very sensitive to high voltages which can occur due to friction of the clothing.

→ Do not touch plug contacts or electronic components!

Risk of Destruction Due to Mechanical Overload

Rigid mounting will give rise to constraining forces which will permanently overload and damage the bearings.

→ Never restrict the freedom of movement of the encoder! Use only the enclosed sheet metal springs or a suitable coupling to secure the unit!

Risk of Destruction Due to Mechanical Shock

Violent shocks, e.g. due to hammer blows, can lead to the destruction of the optical sensing system and the ball bearings.

→ Never use force! Assembly is simple provided that correct procedures are followed.

Risk of Destruction Due to Overloading

→ The unit may only be operated within the limits specified in the technical data.

Fields of Application: industrial Processes and Controls.

→ Over voltage at the connecting terminals must be limited to overvoltage-class-II values (SELV).

→ The connecting cable is not for dragline mounting, only for fixed mounting of the encoder.

→ This encoder is a supply part destined for mounting to other equipment (motor, machine). It is not provided for direct sale to the end customer.

→ Manufacturers integrating this encoder to their facilities are responsible for compliance with CE guidelines and for proper use of the CE mark.

TABLE OF CONTENTS

Preface.....	Page 1
Safety.....	Page 1
Specifications.....	Page 2
Ordering Information.....	Page 2
Dimensions.....	Page 3
Mounting.....	Page 5
Mechanical Data.....	Page 5
Electrical Data.....	Page 5
Connections.....	Page 6
Diagnostics.....	Page 6

SPECIFICATIONS

STANDARD OPERATING CHARACTERISTICS:

Code: Absolute, Optical
Resolution Single-turn: 12 - 22 Bit
Resolution Multi-turn: 12 Bit
Linearity: ±½ LSB up to 14 Bit
Absolute Accuracy (typ.): ±35 arc-sec or ±0.01°
Repeatability (typ.): ±10 arc-sec or ±0.003°
ELECTRICAL:
Interface: EtherNet/IP
Version: Composit Test Revision CT16 Compliant
Output Code: Binary
Input Voltage: 7 - 30 VDC
Current w/o load (typ.): 24V: 60mA (ST) 70 mA (MT)
Current w/o load (max.): (ST/MT) 225 mA
Device Data: Position, Velocity, Acceleration, Alarms
Configuration Options: Resolution, Total Measuring Range, Preset, Direction, Scaling, Position-Velocity-Acceleration Limits
Request Packet Interval (RPI): 1ms
Device Level Ring: Supported
IP Address Conflict Detection: Supported
Noise Immunity: Tested to EN61326-1
Electrical Immunity: Tested to EN61326-1
Termination: Bus cover with 3x M12 connectors

MECHANICAL

Shaft Diameter: 6-12mm (solid shafts),
 9.52mm – 14mm (hub shafts)
Mounting Flanges: Servo Flange, Clamping Flange,
 Tether Flange, Square Flange
Shaft Load (axial / radial): 40 N / 80 N
Axial/Radial Endplay of Mating Shaft (Hub Shaft only):
 ±1.5 mm, ±0.2 mm
Maximum Speed: 10,000 RPM (continuous duty),
 max. 12,000 RPM (short term)
Starting Torque (at 20 °C): typ. ≤ 0.05 Nm (lower
 values available upon request)
Moment of Inertia: ca. 3.8 x 10⁻⁶ kgm²
Housing Material: Aluminum or Stainless Steel
Shaft Material: Stainless Steel
Disc Material: Glass
Weight (approx.): (Aluminum) 14.8 oz. (420 g)
 ST/ 15.9 oz. (450 g) MT
 (Stainless) 2.6 lb (1180 g)

ENVIRONMENTAL

Operating Temperature: -40 °C ... +85 °C
Storage Temperature: -40 °C ... +85 °C
Shock: 400g, 4000 m/s² (6 ms)
Vibration: 30g, 300 m/s² (10 - 2000 Hz)
Humidity: Up to 75%, (no condensation allowed)
Enclosure Rating: IP64 or IP67
General Design: As per DIN EN 61010-1,
 protection class III, contamination level 2,
 overvoltage class II

Ordering Information

To order, complete the model number with code numbers from the table below:

Code 1: Model	Code 2: Resolution	Code 3: Mounting	Code 4: Shaft Size	Code 5: Protocol	Code 6: Electrical	Code 7: Connector	Code 8: Housing
AI25	<input type="checkbox"/> <input type="checkbox"/> <input type="checkbox"/> <input type="checkbox"/>	<input type="checkbox"/>	<input type="checkbox"/>	W	2	R	<input type="checkbox"/> <input type="checkbox"/>
AI25 Size25 Absolute Encoder	0012 12 Bit ST 0013 13 Bit ST 0014 14 Bit ST 0016 16 Bit ST 0017 17 Bit ST 0018 18 Bit ST 0019 19 Bit ST 0020 20 Bit ST 0022 22 Bit ST 1212 12 Bit MT, 12 Bit ST 1213 12 Bit MT, 13 Bit ST 1214 12 Bit MT, 14 Bit ST 1216 12 Bit MT, 16 Bit ST 1217 12 Bit MT, 17 Bit ST 1218 12 Bit MT, 18 Bit ST 1219 12 Bit MT, 19 Bit ST 1220 12 Bit MT, 20 Bit ST 1222 12 Bit MT, 22 Bit ST	Available when Code 4 is 0 or A 0 Servo* Available when Code 4 is 1, 2, 8, 9 or B, C, H and J 1 Clamping* Available when Code 4 is 1,2 or B, C 2 Square Flange** Available when Code 4 is 3, 4, 5, 6, 7 or E 3 Hubshaft w/ Tether† * 58mm Dia. ** 2.5" Square † 63mm BC	w/o Shaft Seal (IP64) 0 6 mm 1 3/8" 2 10 mm 3 3/8" Hubshaft 4 12 mm Hubshaft 5 1/2" Hubshaft 6 10 mm Hubshaft 7 14 mm Hubshaft†† 8 12 mm†† 9 8 mm†† w/ Shaft Seal (IP67) A 6 mm B 3/8" C 10 mm E 12 mm Hubshaft H 12 mm†† J 8 mm†† †† Available only upon request	W EtherNet/IP	2 7-30 VDC	R Bus Cover with 3 M12 Connectors (1x Male + 2x Female)	Available when Code 3 is 2 and Code 4 is B or C Blank Aluminum SS Stainless Steel

M12 CABLE ASSEMBLIES

Part Number	Description	Standard Lengths (m)
608555-XXXX	M12 Male to RJ45	1,2,5,10,20,30,50,100
608556-XXXX	M12 Female to Flying Leads	1,2,5,10,20,30,50,100
608557-XXXX	M12 Male to M12 Male	1,2,5,10,20,30,50,100
608600-XXXX	M12 Male to Flying Leads	1,2,5,10,20,30,50,100

Note: 10 meter cable will be -0010

ELECTRICAL CONNECTIONS
Bus cover with 3x M12 connectors

Pin	P1	Supply voltage	P2
1	TxD+	7-30V in	TxD+
2	RxD+	N.C.	RxD+
3	TxD-	0 V in	TxD-
4	RxD-	N.C.	RxD
Shield	Shield ¹	Shield ¹	Shield ¹

¹Shield connected to encoder housing

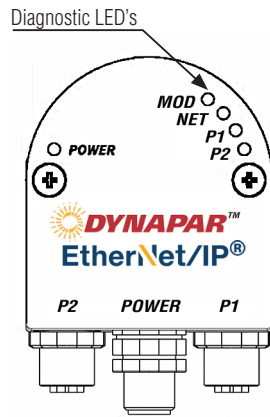

DIMENSIONS

Clamping Flange

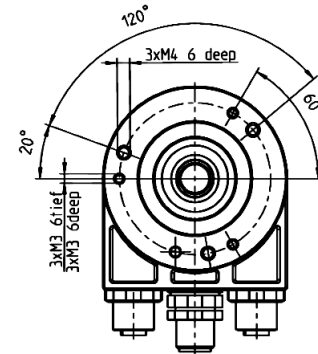
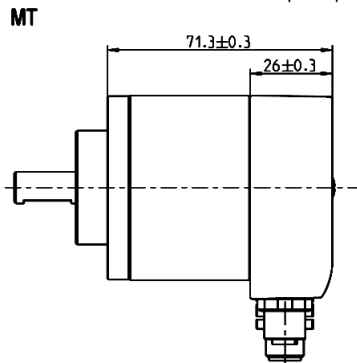
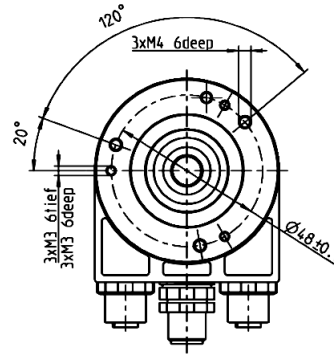
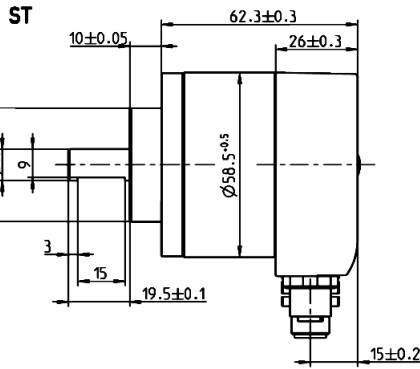
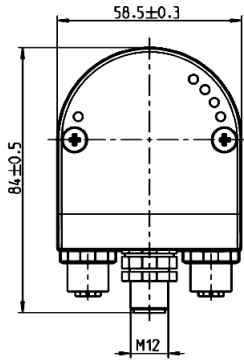

	Mass/dimension	
Wellen-ØA/shaft-ØA	10 ^{+0.01} _{-0.02}	9.52 ^{+0.01} _{-0.02}
Code/code	"2"	"6"

Square Flange - Aluminum (shown)

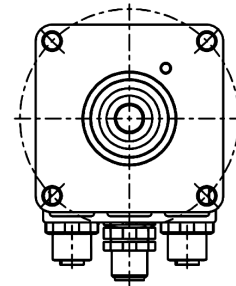
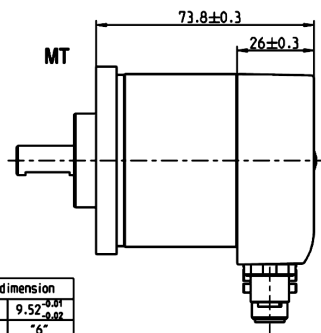
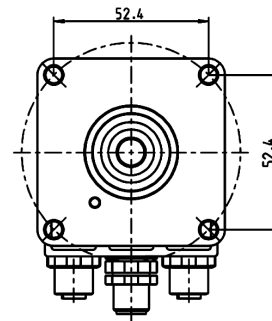
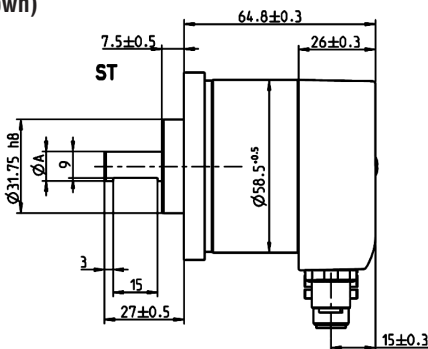
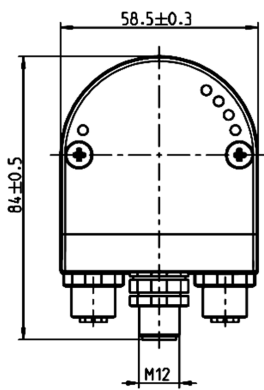

	Mass/dimension	
Wellen-ØA/shaft-ØA	10 ^{+0.01} _{-0.02}	9.52 ^{+0.01} _{-0.02}
Code/code	"2"	"6"

DIMENSIONS Servo Flange

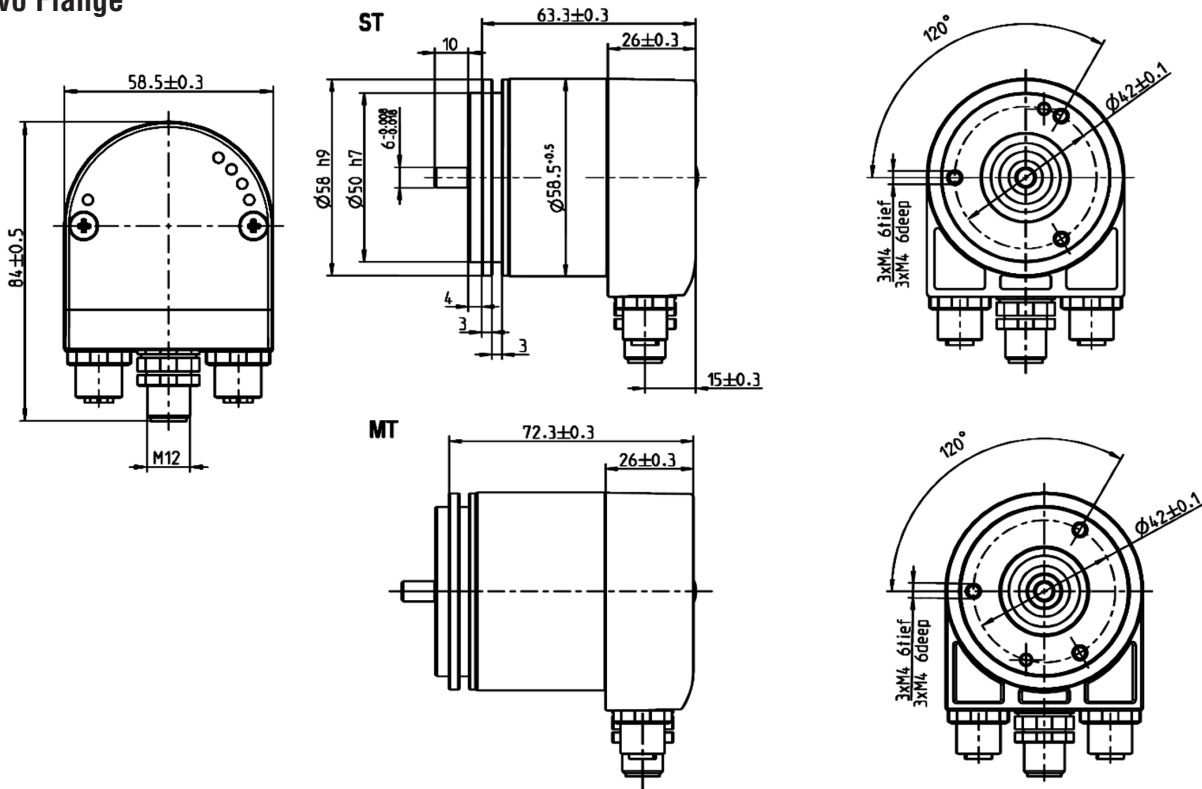

Hub Shaft

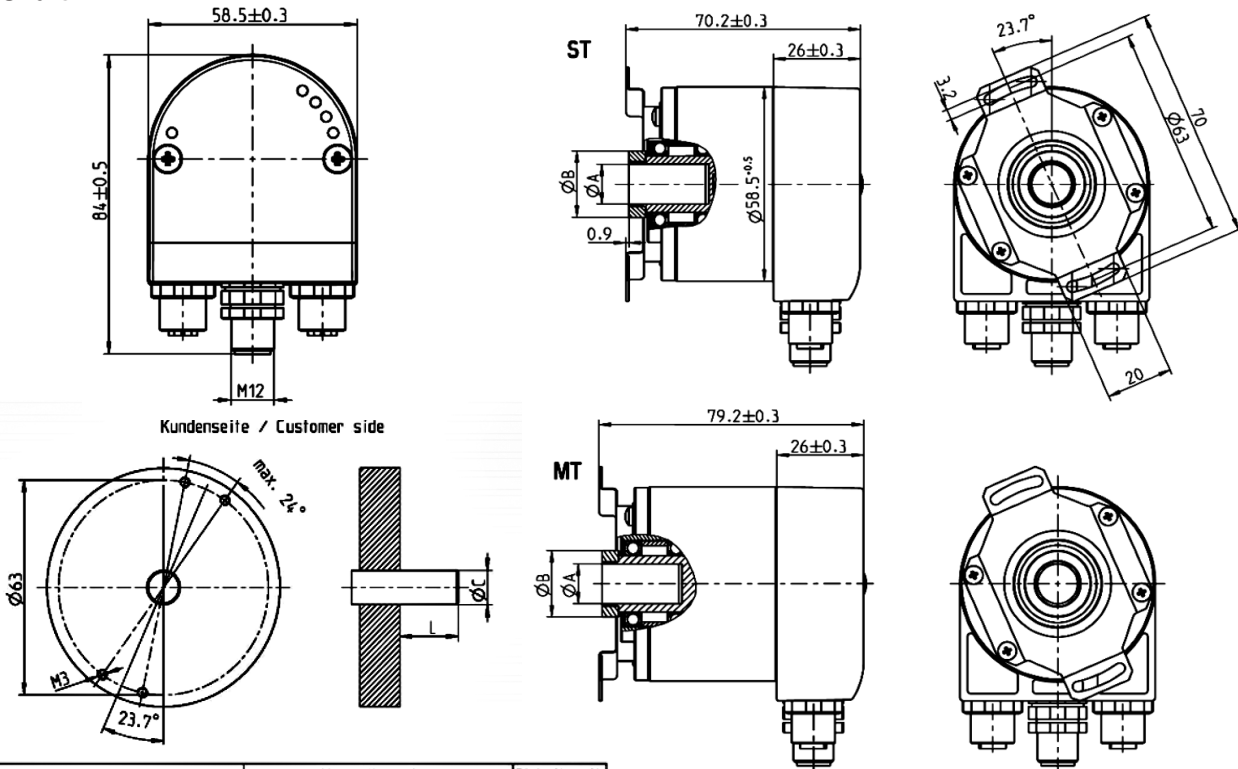

	Mass/dimension				Einheit/Unit
Hohlwellen- \varnothing A/hollow shaft- \varnothing A	10 ^{+0.012}	12 ^{+0.012}	9.52 ^{+0.012}	12.7 ^{+0.012}	mm
Anschlusswellen- \varnothing C/connecting shaft- \varnothing C	10 _{g7}	12 _{g7}	9.52 _{g7}	12.7 _{g7}	mm
Klemmring- \varnothing B/clamping ring- \varnothing B	18	20	18	22	mm
L min.	15	18	15	18	mm
L max.	20	20	20	20	mm
Wellen-Code / shaft code	"2"	"7"	"6"	"E"	

L = Eintauchtiefe der Anschlusswelle in den Geber
L = Length of customers shaft inside of encoder

MOUNTING

A Square flange

B Spring plate, hollow shaft

C Synchro flange

D Clamping flange

MECHANICAL DATA

$d = 6 \dots 12 \text{ mm:}$ $F_r = 80 \text{ N}$ $F_a = 40 \text{ N}$		
	- Short term	$= 12\,000 \text{ min}^{-1}$
	- Continuous duty	$= 10\,000 \text{ min}^{-1}$
	$-40 \dots +85 \text{ }^\circ\text{C}$	
-Vibration -Shock	$300 \text{ m/s}^2 (10 - 2000 \text{ Hz})$ $4000 \text{ m/s}^2 (6 \text{ ms})$	

ELECTRICAL DATA

	Singleturn	Multiturn
$U_{in}^{1)} =$	7...30VDC	7...30VDC
I_{max} typ. (only Encoder) @ 24 VDC	60 mA	70 mA
I_{max} (incl. Output) = Fuse	1 A Middle slow blow	1 A Middle slow blow
- Interface	EtherNet - IP	
- Cable length		
ESD		



Connecting the encoder to a DC line voltage without a protective circuit for EMC is not allowed.

CONNECTION DIAGRAMS

Bus cover with 3x M12 connectors

Pin	P1	Supply Voltage	P2
1	TxD+	7-30V in	TxD+
2	RxD+	N.C.	RxD+
3	TxD-	0 V in	TxD-
4	RxD-	N.C.	RxD
Shield	Shield ¹	Shield ¹	Shield ¹

¹Shield connected to encoder housing

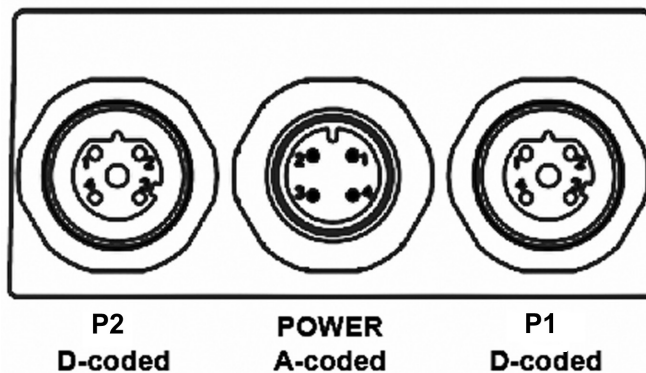

DIAGNOSTIC LEDS

Indicator	Status	Meaning
Module LED	OFF	No Power
	Solid Green	Device Running (Operational)
	Green Flashing	Standby / Device Not Configured / no IP Address assigned
	Red Flashing	Warning or Firmware Upgrade in Progress
	Solid Red	No IP / Fault / Error / Device Not Operational
	Green / Red Flashing	Self-Test at Power On
Network LED	OFF	No Power
	Solid Green	CIP Connection available
	Green Flashing	No CIP Connection
	Red Flashing	Connection Timeout
	Solid Red	IP-Address Conflict
	Green / Red Flashing	Self-Test at Power On
P1 & P2 LED	OFF	No Ethernet Connection
	Solid Green	Active Ethernet Connection

Diagnostic LED's

