

This product has been discontinued.
Please contact Dynapar for assistance.
1-800-873-8731
www.dynapar.com



- **For motor or shaft assembly mounting**
- **Self-aligning up to 2500 PPR with optional marker pulse**
- **Easy to install**
- **Shielded cable and line driver options**

The Series M20 is a cost-effective, modular encoder ideal for sensing angular speed, direction of rotation, and position. It is designed for fast and simple over-the-shaft mounting on motors and shaft assemblies. Series M20 encoders are available in a choice of eight sizes for English or metric sized shafts. Series M20's collimated LED light source and radial in-line sensor array minimize performance variations caused by radial and axial shaft endplay. Reduced component count and state-of-the-art opto-electronic technology help ensure long-term performance in spite of variations in supply voltage, temperatures and component aging.

Optional shielded cable and differential line driver outputs allow for longer cable runs and/or higher electrical noise immunity.

Typical Applications

- Machine tools
- Robotics
- Positioning tables
- Material handling equipment
- Shop-floor computer peripherals
- Printers/Plotters
- Automatic test equipment

Mechanical and Environmental Features

- Industry standard mounting: 2 PLC's on 1.812 dia. B.C.
- Fast over-the-shaft mounting
- Units for through-shaft mounting available with dust shields
- Up to 12,000 RPM
- One piece rotor/stator assembly and snap-on cover
- Up to 70°C operating temperatures

Electrical Features

- Choice of 5, 12, or 15 VDC operating voltage
- Higher electronic operating speeds (up to 100 kHz data and 50 kHz for marker pulse)
- Factory set phase symmetry and index pulse duration
- No field potentiometer adjustments
- Waveform phasings can be easily optimized at final test for higher speed/higher resolution applications.

Mechanical Interface Application Considerations

- Shaft length: .50" min. (over .70" requires thru-hole in cover).
- Shaft run-out not to exceed: 0.001" T.I.R. max. for encoder PPR's up to 1024; or 0.0005" T.I.R. max. for encoder PPR's greater than 1024, in order to maintain encoder accuracy specifications (see below).
- Shaft to be perpendicular within .005 T.I.R. to motor surface where encoder is to be mounted.
- Shaft endplay 0.002 max.
- Mounting hole accuracy: within 0.005 of true position
- Shaft dia. tolerance: -0.0003 to -0.0006" Example: for 3/8" dia. hub, shaft size = 0.3747/0.3744

SPECIFICATIONS

Electrical

Code: Incremental, quadrature

Accuracy: ±2.0 arc minutes worst case pulse to any other pulse

Output Voltage: Single ended; Logic "1": $V_{cc} - 2V$ min.; at 10 mA source; Logic "0": 0.4 Volts max. at 20 mA sink

Differential Line Driver: TC4428; 40 mA sink/source

Edge Separation: 60° min.

Index: 225 ±90°

Input Power Requirements:

Standard 5, 12, or 15 VDC ±5%: 90 mA max.

Line Driver 5, 12, or 15 VDC ±5%: 200 mA max.

Frequency Response: Count channels 100 kHz, Index channel 50 kHz

Illumination Source: Solid state LED, collimated

Connector and Cable: Choice of 1) Berg #66902, 10-pin connector, 10-conductor ribbon, 18" length standard, 28 AWG with .050 pitch or 2) shielded cable with no connector

Mechanical

Rotation: CW and CCW

Hub I.D. Tolerance: +.0001/-0.0002

Base and Cover Material: Rugged polycarbonate

Moment of Inertia: 1.3 x 10⁻⁴ oz-in sec²

Disc Material: Chrome pattern on glass

Acceleration: 500,000 rad/sec² max.

Velocity: 12,000 RPM max.

Weight: 1.5 oz.

Environmental

Operating Temperature: 0° to +70°C

Storage Temperature: -40° to +80°C

Relative Humidity: to 90% non-condensing

MTBF: 360K hours @ 25°C; 130K hours @ 55°C; 40K hours @ 70°C

Vibration: Mil. Std. 810B, Curve W

Shock: 50 G's for 11 msec. duration

Enclosure Rating: NEMA 12 / IP54

Approximate Dimensions (in inches)

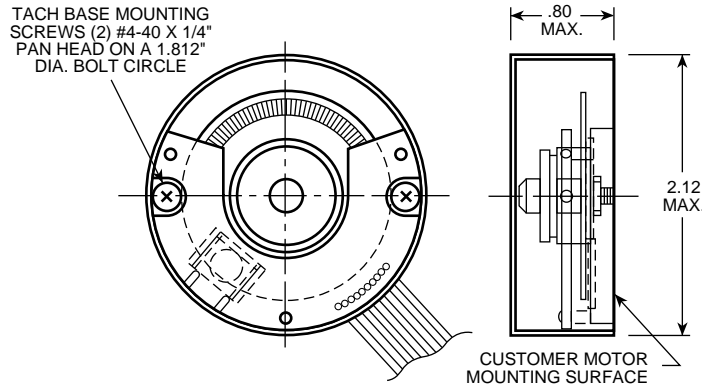

Electrical Connections

Ribbon Cable Terminations		
Pin #	Standard Output	Line Driver
	Function (If Used)	Function (If Used)
1	Signal A	Signal A
2	Supply	Signal A
3	Common	Signal Z
4	No Connection	No Connection
5	No Connection	No Connection
6	Common (Optional)	Common
7	Supply (Optional)	Supply
8	Signal B	Signal B
9	Supply (Optional)	Signal B
10	Signal Z	Signal Z

Shielded Cable Terminations		
Wire Color Code	Standard Output	Line Driver
	Function (If Used)	Function (If Used)
Red	Supply	Supply
Black	Common	Common
Green	Signal A	Signal A
Orange	Signal B	Signal B
White	Signal Z	Signal Z
Red/Blk	–	Signal A
Wht/Blk	–	Signal B
Blue	–	Signal Z
Bare	Shield	Shield

Installation Tools: A #2-56 spline wrench is recommended for securing the hub assembly to the shaft. A reusable wrench (included with each M20) is available separately by ordering kit part number M20-N1.

Ordering Information

To order, complete the model number with code numbers from the table below:

Code 1: Model	Code 2: Pulses/Rev	Code 3: Cover	Code 4: Output	Code 5: Electrical	Code 6: Hub	Code 7: Termination	
M20	<input type="checkbox"/> <input type="checkbox"/> <input type="checkbox"/> <input type="checkbox"/>	<input type="checkbox"/>	<input type="checkbox"/>	<input type="checkbox"/>	<input type="checkbox"/>	<input type="checkbox"/>	
M20 Size 20 Modular	0001 0010 0012 0050 0060 0100 0120 0125 0150 0180 0192 0200 0250 0256 0300 0360 2500	0400 0480 0500 0512 0600 0720 0800 0900 1000 1024 1200 1250 1270 1500 1800 2000	0 Enclosed (no hole), End-of-Shaft Mount 1 Through Hole 2 Through Hole with Dust Seal	0 Single Ended, Bidirectional, no Index 1 Single Ended, Bidirectional, with Index 2 Differential, Bidirectional, no Index 3 Differential, Bidirectional, with Index	available when Code 4 = 0 or 1: 0 5 VDC 1 12 VDC 2 15 VDC available when Code 4 = 2 or 3: 3 5V Line Driver 4 12V Line Driver 5 15V Line Driver	0 1/4" 1 3/8" 2 7/16" 3 1/2" 4 6 mm 5 8 mm 6 10 mm 7 12 mm	0 18" Ribbon Cable 1 18" Shielded Cable