

NEW

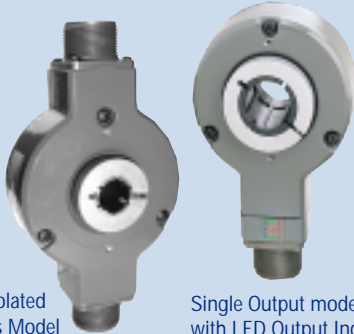

Dual Isolated
Outputs Model

Single Output model shown
with LED Output Indicators



Hazardous Location Certification Available
Class I, Division 2, Groups A, B, C & D
Class II, Division 2, Groups F & G

Harsh-Duty Optical Encoder

DESCRIPTION

The Series HS35 Sealed Hollowshaft is equipped with an unbreakable disk that meets the demands of the most severe shock and vibration generating processes. Its floating shaft mount and spring tether eliminate bearing loads and flexible shaft couplings to eliminate wear and maintenance.

Series HS35 has complete electrical protection from over-voltage, reverse voltage, and output short circuits. In addition, the Series HS35 is not only electrically & thermally isolated, but also environmentally sealed with shaft seals at both ends.

The encoders can be provided with optional hazardous location certification that allows use in environments stated in: Class I, Division 2, Group A: atmospheres such as acetylene; Class I, Division 2, Group B: atmospheres such as hydrogen; Class I, Division 2, Group C: atmospheres such as ethyl ether and ethylene; Class I, Division 2, Group D: atmospheres such as acetone, ammonia, benzene, butane, cyclopropane, ethanol, gasoline, hexane, methanol, methane, natural gas, naphtha, and propane. Class II, Division 2, Group F & G. Classifications of hazardous locations are subject to the approval of the authority having jurisdiction. Refer to Article 500 of the National Electrical Code (NEC) or Section 18 of the Canadian Electrical Code (CEC).

Note: For CSA Division 2, Group F & G, certification, Dynapar Adapter Kit P/N 114064-0001 must be used.

Series HS35

- Sealed Hollow Shaft design eliminates mounting bracket, flexible shaft coupling and installation labor
- Redesigned one-piece hub for less runout and jitter
- Can accommodate up to 1-1/4" diameter shaft
- New more rigid unbreakable disk in 1024 and 2048 PPR
- New seals and gasketed cover for IP67 rating
- Electrically isolated and Thermally insulated
- Hazardous Location Certification Available

APPLICATIONS:

The Dynapar brand Series HS35 Sealed Hollowshaft encoder is designed for easy installation on motor or machine shafts. Its hollowshaft design eliminates the need for a flexible shaft coupling, mounting bracket, flower pot, or flange adapter. This not only reduces the installation depth, but also lowers total cost. A hazardous location certification option can be provided when the environment requires NEC/CEC, Class 1 & 2, Division 2 classification.

- Converting Machinery
- Material Handling
- Packaging Equipment
- Pickling Equipment
- Processing Equipment

INDUSTRIES

Chemical, Food & Beverage, Oil & Gas, Paper, Steel and any other where a precise encoder is needed. Optional NEC/CEC, Class 1, Division 2 classification for operation in hazardous environments.

FEATURES/BENEFITS

Mechanical and Environmental

- Unbreakable code disk
- Flexible mounting
- Eliminated bearing loads
- Insulated from motor housing/shaft temperatures to 125°C
- Heavy duty shaft seals; Sealed connector

Electrical

- Overvoltage, reverse voltage, & output short circuit protection
- Noise immunity to EN50082-2

Harsh-Duty Optical Encoder

Series HS35

Harsh-Duty Optical Encoder... Meets Stringent Washdown Requirements

SPECIFICATIONS

STANDARD OPERATING CHARACTERISTICS

Code: Incremental
Resolution: 1 to 2500 PPR (pulses/revolution)
Accuracy: (worst case any edge to any other edge) ±7.5 arc-min.
Format: Two channel quadrature (AB) with optional Index (Z) and complementary outputs
Phase Sense: A leads B for CW shaft rotation viewing the shaft clamp end of the encoder
Quadrature Phasing: 90° ± 22.5° electrical
Symmetry: 180° ± 18° electrical
Index: 180° ± 18° electrical (gated with B low)
Waveforms: Squarewave with rise and fall times less than 1 microsecond into a load capacitance of 1000 pf

ELECTRICAL

Input Power: (each output)
 4.5 min. to 26 VDC max. at 100 mA max., not including output loads
Outputs:
 7273 Open Collector: 30 VDC max., 40 mA sink max.
 7272 Push-Pull and Differential Line Driver: 40 mA sink or source
 4469 Differential Line Driver: 100 mA sink or source

Frequency Response: 100 kHz min.
Electrical Protection: Overvoltage, reverse voltage and output short circuit protected
Noise Immunity: Tested to EN50082-2 (Heavy Industrial) for Electro Static Discharge, Radio Frequency Interference, Electrical Fast Transients, Conducted and Magnetic Interference

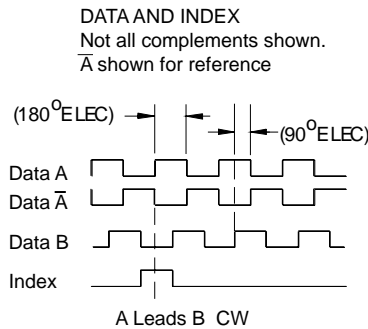

Mating Connector:
 6 pin, style MS3106A-14S-6S (MCN-N4);
 7 pin, style MS3106A-16S-1S (MCN-N5);
 10 pin, style MS3106A-18-1S (MCN-N6)
 5 pin, style M12: Cable with connector available
 8 pin, style M12: Cable with connector available

MECHANICAL

Bearing Life: 80,000 hours at 3600 RPM; 128,000 hours at 1800 RPM
Shaft Loading: 40 lbs. radial, 30 lbs. axial
Shaft Speed: 3600 RPM max. (Important: see Operating Temperature derating for >1800 RPM)
Shaft Bore Tolerance: Nominal +0.0003"/+0.0005" (+0.008/+0.013 mm)
Mating Shaft Requirements:
 Runout: ±0.025" (0.63 mm) radial typical ;
 Endplay: ±0.050" (1.27 mm) axial typical ;
 Minimum: 1.25" (32 mm) recommended;
 Maximum: 2.0" (51 mm) to fit inside cover;
 Solid shaft recommended; keyway allowed; flatted shaft should not be used
Starting Torque: 5.0 oz-in max.
Running Torque: 4.5 oz-in max.
Moment of Inertia:
 ≤ 5/8" bore: 7.9 x 10⁻⁴ oz-in-sec²
 > 5/8" bore: 25.6 x 10⁻⁴ oz-in-sec²
Weight: 16 oz. max.

ENVIRONMENTAL

Operating Temperature:
Standard: -40 to +70 °C;
Extended: -40 to +100 °C;
 ≤ 5/8" bore: Derate 5 °C per 1000 RPM above 1800 RPM;
 > 5/8" bore: Derate 10 °C per 1000 RPM above 1800 RPM.
Storage Temperature: -40 to +90 °C
Shock: 50 Gs for 11 milliseconds duration
Vibration: 5 to 2000 Hz at 20 Gs
Humidity: to 98% without condensation
Enclosure Rating: NEMA4/IP67
Hazardous Location Certification:
 Available as Optional Feature. Class I, Division 2, Group A, B, C & D. CSA File No. LR86404

ELECTRICAL CONNECTIONS

6, 7 & 10 Pin MS Connectors and Cables - Code 7= 0 to 8, A to G

Connector & mate/accessory cable assembly pin numbers and wire color information is provided here for reference. HS35 models with direct cable exit carry the same color coding as shown for each output configuration.

Encoder Function	Cable #108594-* 6 Pin Single Ended		Cable #112123-* 6 Pin Dif Line Drv w/o Id x		Cable #108596-* 7 Pin Dif Line Drv w/o Id x		Cable #108595-* 7 Pin (If Used)		Cable #1400635-* 10 Pin (If Used)		Cable #108615-* 12 Pin CCW (If Used)	
	Pin	Wire Color	Pin	Wire Color	Pin	Wire Color	Pin	Wire Color	Pin	Wire Color	Pin	Wire Color
	Sig. A	F	BRN	E	BRN	A	BRN	A	BRN	A	BRN	5
Sig. B	D	ORN	D	ORN	B	ORN	B	ORN	B	ORN	8	ORN
Sig. Z	C	YEL	—	—	—	—	C	YEL	C	YEL	3	YEL
Power +V	B	RED	B	RED	D	RED	D	RED	D	RED	12	RED
N/C	F	—	—	—	—	—	E	—	E	—	7	—
Com	A	BLK	A	BLK	F	BLK	F	BLK	F	BLK	10	BLK
Case	—	—	—	—	G	GRN	G	GRN	G	GRN	9	—
Sig. A	—	—	C	BRN/WHT	C	BRN/WHT	—	—	H	BRN/WHT	6	BRN/WHT
Sig. B	—	—	F	ORN/WHT	E	ORN/WHT	—	—	I	ORN/WHT	1	ORN/WHT
Sig. Z	—	—	—	—	—	—	—	—	J	YEL/WHT	4	YEL/WHT
0V Sense	—	—	—	—	—	—	—	—	—	—	2	GRN
5V Sense	—	—	—	—	—	—	—	—	—	—	11	BLK/WHT

5 & 8 Pin M12 Accessory Cables when Code 7= H or J

Connector pin numbers and cable assembly wire color information is provided here for reference.

Encoder Function	Cable # 112859- 5 Pin Single Ended		Cable # 112860- 8 Pin Single Ended		Cable # 112860- 8Pin Differential	
	Pin	Wire Color	Pin	Wire Color	Pin	Wire Color
Sig. A	4	BLK	1	BRN	1	BRN
Sig. B	2	WHT	4	ORG	4	ORG
*Sig. Z	5	GRY	6	YEL	6	YEL
Power +V	1	BRN	2	RED	2	RED
Com	3	BLU	7	BLK	7	BLK
Sig. A	—	—	—	—	3	BRN/WHT
Sig. B	—	—	—	—	5	ORG/WHT
*Sig. Z	—	—	—	—	8	YEL/WHT

* Index not provided on all models. See ordering information
Cable Configuration: PVC jacket, 105 °C rated, overall foil shield; 24 AWG conductors, minimum

Harsh-Duty Optical Encoder

Series HS35

Harsh-Duty Optical Encoder... Meets Stringent Washdown Requirements

DIMENSIONS Inches [mm]

Dimensions

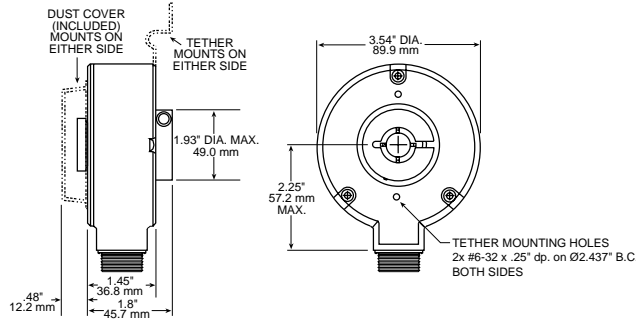

Code 4: Fixing

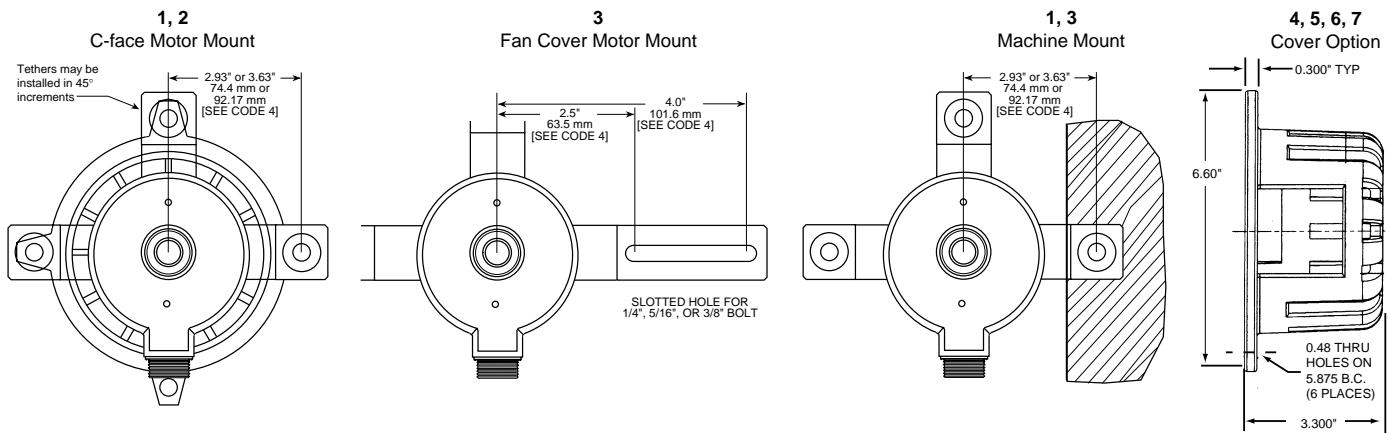

Code 7: Termination

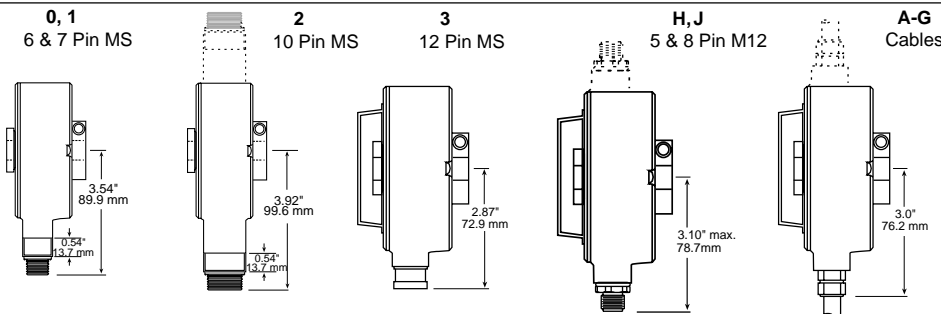

6 & 7 Pin and 10 Pin shown with LED Output Indicator Option - Code 8: PS

Specifications are for base models with standard features only unless otherwise noted. Specifications subject to change without notice in accordance with our DBS policy of continuous improvement.

All product and brand names are trademarks of their respective owners. All rights reserved.

Dynapar™ brand is a trademark of DYNAPAR.

All rights reserved.
©2008 DYNAPAR

HS35 Data Sheet (9/08)

ORDERING INFORMATION

Code 1: Model	Code 2: PPR	Code 3: Bore Size	Code 4: Fixing	Code 5: Format	Code 6: Output	Code 7: Termination	Code 8: Options
HS35	<input type="checkbox"/> <input type="checkbox"/> <input type="checkbox"/> <input type="checkbox"/>	<input type="checkbox"/>	<input type="checkbox"/>	<input type="checkbox"/>	<input type="checkbox"/>	<input type="checkbox"/>	<input type="checkbox"/> <input type="checkbox"/>
Ordering Information							
HS35 Size 35 heavy-duty, sealed hollowshaft encoder	0001 0500	0 6 mm	0 None - customer supplied	0 single ended, unidirectional (A)	0 5-26V in, 5-26V open collector out	0 6 pin connector	D2 Hazardous Location Certified
	0003 0512	1 1/4"	1 Clearance hole for 3/8" bolt on 5.88" dia. bolt circle	1 single ended, bidirectional (AB)	1 5-26V in, 5-26V open collector out w/ 2.2kΩ pullups	1 7 pin connector	available when Code 7 is 2
	0010 0600	2 5/16"	2 Clearance hole for 1/2" bolt on 7.25" dia. bolt circle	2 single ended, bidirectional with index (ABZ)	2 5-26V in, 5-26V push-pull out	2 10 pin connector	
	0012 0900	3 8 mm	3 Slotted hole for bolt on 2.5" to 4.0" radius	3 differential, bidirectional (AA BB)	3 5-26V in, 5V line driver out (7272)	3 12 pin connector	D3 Same as D2 including adapter for CSA Div. 2, Group F & G Certification (see specifications) Note: Requires use of Mating Cable Assembly 114074-XXXX available when Code 7 is 0 or 5 and Code 5 is 0-2, or Code 7 is 1, 2, 6, 7: PS LED Output Indicator <i>Not provided with "Hazardous Location Certified" Option</i>
	0050 1000	4 3/8"	4 Available when Code 5 is 0-4:	4 differential, bidirectional with index (AA BB ZZ)	4 5-26V in, 5-26V line driver out (7272)	5 6 pin connector, plus mating connector	
	0060 1024	5 10 mm	5 Available when Code 5 is 5:	5 Dual isolated differential, bi-directional w/index (AABBZZ)	5 5-26V in, 5V Differential Line Driver out (4469)	6 7 pin connector, plus mating connector	
	0064 1200	6 12 mm	6 Same as '1' w/ dual cover kit		6 5-15V in, 5-15V Differential Line Driver out (4469)	7 10 pin connector, plus mating connector	
	0100 1270	7 1/2"	7 Same as '3' w/ dual cover kit		A same as '3' with extended temp. to 100°C	8 12 pin connector, plus mating connector	
	0120 1500	8 5/8"			B same as '4' with extended temp. to 100°C	A 18" (.5m) cable	
	0240 1800	9 15 mm				B 36" (1m) cable	
0250 2000	A 16 mm				C 72" (2m) cable		
0300 2048	B 19 mm				D 10' (3m) cable		
0360 2400	C 3/4"				F 13" (.3m) cable with 10 pin connector plus mating connector		
	D 20 mm				G 13" (.3m) cable		
	E 7/8"				J 8 Pin M12 Connector		
	F 24 mm				available when Code 5 is 0 thru 2		
	G 1"				H 5 Pin M12 Connector		
	H 1-1/8"						
	P 1-1/4"						

109473-0001 Tether kit (clearance hole for 3/8" bolt on 5.88" dia. bolt circle)
 109473-0002 Tether kit (clearance hole for 1/2" bolt on 7.25" dia. bolt circle)
 109473-0003 Tether kit (slotted hole for bolt on 2.5" to 4.0" radius)
 112121-0001 Spare Hub Clamp (Bore size Code 3: 0 - 9)
 112121-0002 Spare Hub Clamp (Bore size Code 3: A - H)
 110533-0001 Cover Kit, 56C face

110533-0002 Cover Kit, fan cover
 110533-0003 Dual Cover Kit, 56C face
 110533-0004 Dual Cover Kit, fan cover
 114064-0001 Adapter Kit, CSA Division 2, Group F & G, Cert.
 114074-XXXX D3 Mating Cable Assembly. "-XXXX" denotes length in feet; example -0010 equals 10 feet.

With factories around the world, global sales and applications support, and an expansive network of distributors, we stay close to our customers - shortening lead times and fostering responsiveness. Three-day lead time is standard, with same-day shipments available on many of our products.

Headquarters: 1675 Delany Road • Gurnee, IL 60031-1282 • USA
 Phone: +1 847.662.2666 • Fax: +1 847.662.6633

Satellite Locations:
 North America: North Carolina, South Carolina, Connecticut, Massachusetts, New York, Canada, British Virgin Islands • Europe: United Kingdom, Italy, France, Germany, Spain, Slovakia • Latin America: Brazil • Asia: China, Japan, Korea, Singapore

Customer Service:
 Tel.: +1.800.873.8731
 Fax: +1.847.662.4150
 custserv@dynapar.com

Technical Support
 Tel.: +1.800.234.8731
 Fax: +1.847.782.5277
 dynapar.techsupport@dynapar.com



Factory Automation Worldwide Brands: Dynapar™ • Harowe™ • Hengstler™ • NorthStar™